

MOZZO COD.298405000
DA ORDINARE E
SPEDIRE SEPARATEMENTE
HUB COD.298405000 SUPPLIED
AND SHIPPED SEPARATELY

Verniciatura / Painting	
DESIGNAZIONE CLIENTE <i>Customer Designation</i>	Nero / Black RAL 9005
RIF.SPECIFICHE INTERNE <i>B&P Specifications Ref.</i>	STBP02-V STBP06-V
VEDI SCHEMA / <i>See Schema</i>	NY30500006
Solo le specifiche B&P sono completamente soddisfatte <i>Only B&P specifications are completely satisfied</i>	

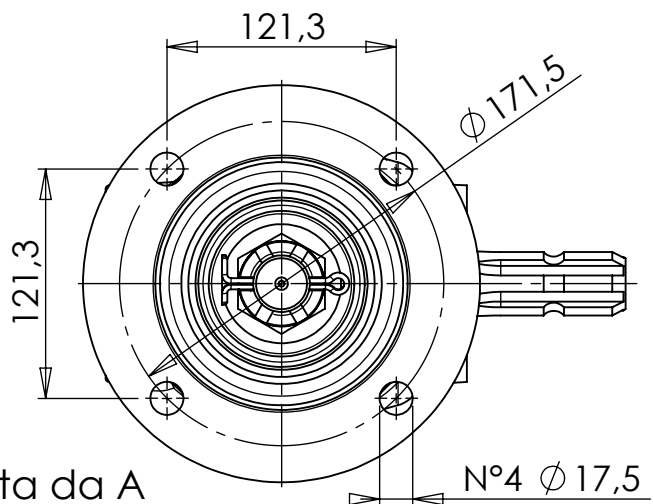

Vista da A
View from A

WARNING!

ROTATING SHAFTS MARKED
ARE NOT SHIELDED.
ANY SHAFT AND COUPLING NOT
GUARDED BY LOCATION MUST BE
SHIELDED BY AN INTERACTIVE
GUARDING SYSTEM.
BONDIOLI & PAVESI DECLINES
RESPONSIBILITY IF PROPER GUARDS
ARE NOT PROVIDED AND MAINTAINED.

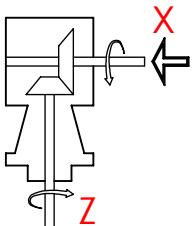

Rev.	Descrizione / Description	Data / Date	Disegnato / Drawn by
MONTAGGIO / GEAR ARRANGEMENTS	RAPPORTO / RATIO	TIPO / TYPE	CLIENTE / CUSTOMER
	1:2.15	3050	3600502 Dani-Tech A/S
	GIRI IN ENTRATA / INPUT SPEED	PESO / WEIGHT (Kg)	DISEGNATO / DESIGNED BY
	540	23.3	M.Pini
	POTENZA IN ENTRATA / INPUT POWER	STUDIO / CONCEPT DRAWING	DATA / DATE
	40 CV - 29 kW		03-10-2016
	RIF.CLIENTE / CUSTOMER REF.	TIPO DI MACCHINA / TYPE OF IMPLEMENT	CODICE / CODE
			S3050215006
			REV.
			0



VIETATE LE RIPRODUZIONI NON AUTORIZZATE REPRODUCTION NOT PERMITTED PROHIBIDA LA RIPRODUCCION NO AUTORIZADA TOUTE REPRODUCTION NON AUTORISEE EST INTERDITE NICHT GENEHMIGTE Vervielfaeligungen sind unzulassig